



Design Guide



Bottle as Art

Perhaps second to the art of wine, is the art of the bottle.

Dare we say the art of the rack follows just behind?

Whether storing a few bottles or several thousands, RESERVE™ is designed to showcase the bottle for easy viewing.

Storing bottles in dusty, cramped cellars is yesterday.

Today, we don't just cellar wine, we celebrate it.

In a room, in a corridor, in a kitchen or next to a sofa. Anywhere.

Big space or small space, wine any place.

Quick Design Guide	1
Design Guide	2
Features	3
5 Bottle Positions	4
Compare Bottle Positions	10
Design Ideas	11
How to Order	20
Too Spartan?	21

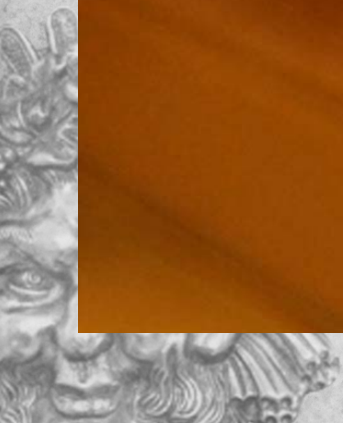
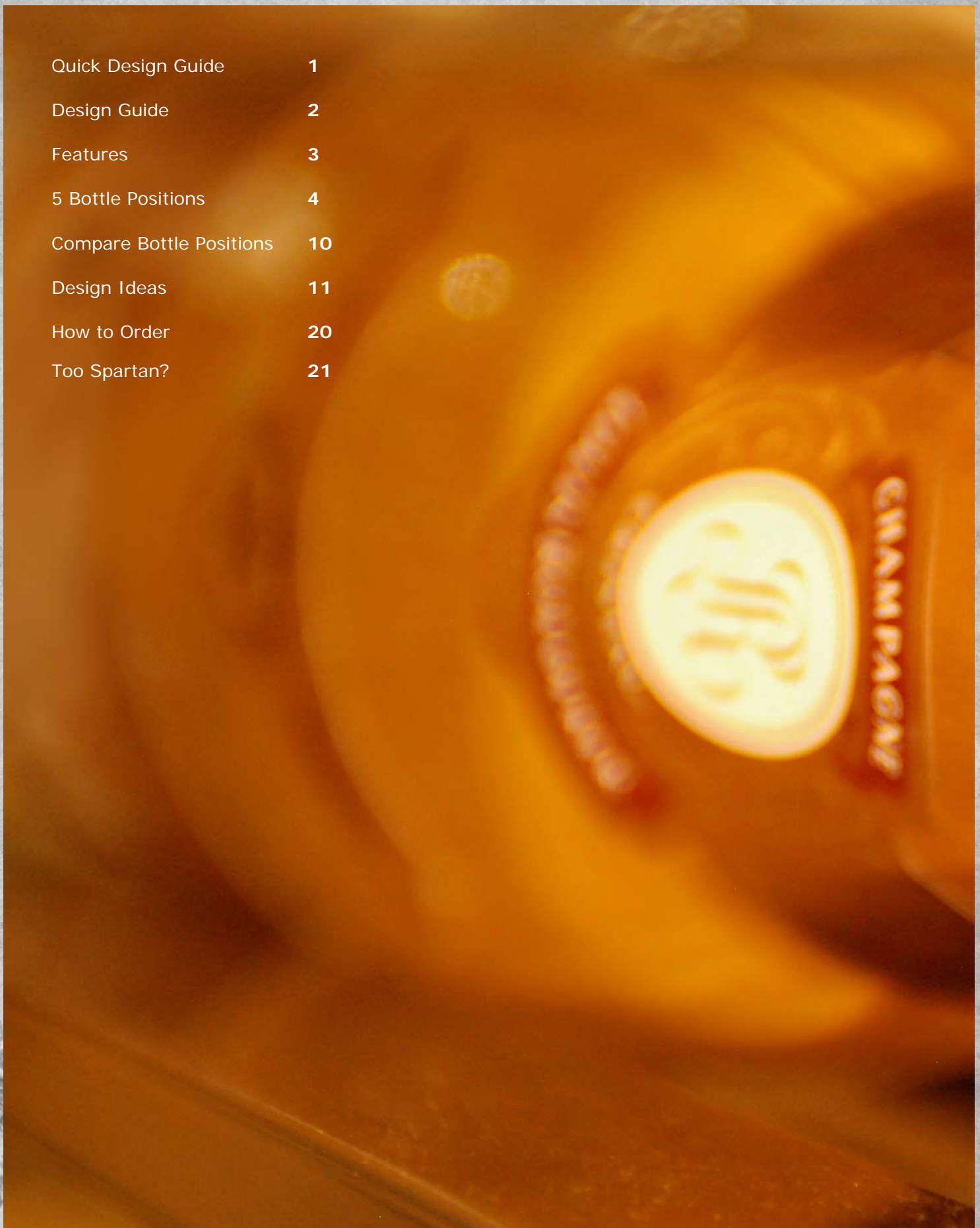

1. Measure the height and width of your installation.
2. RESERVE™ can hold bottles in 5 different “bottle positions”.
3. A RESERVE™ wine rack is comprised of many rows of bottles. Bottles in each row can be in a different “bottle position”.
4. Mixing and matching different “bottle positions” on different rows can make your wine rack more personalized and more functional.

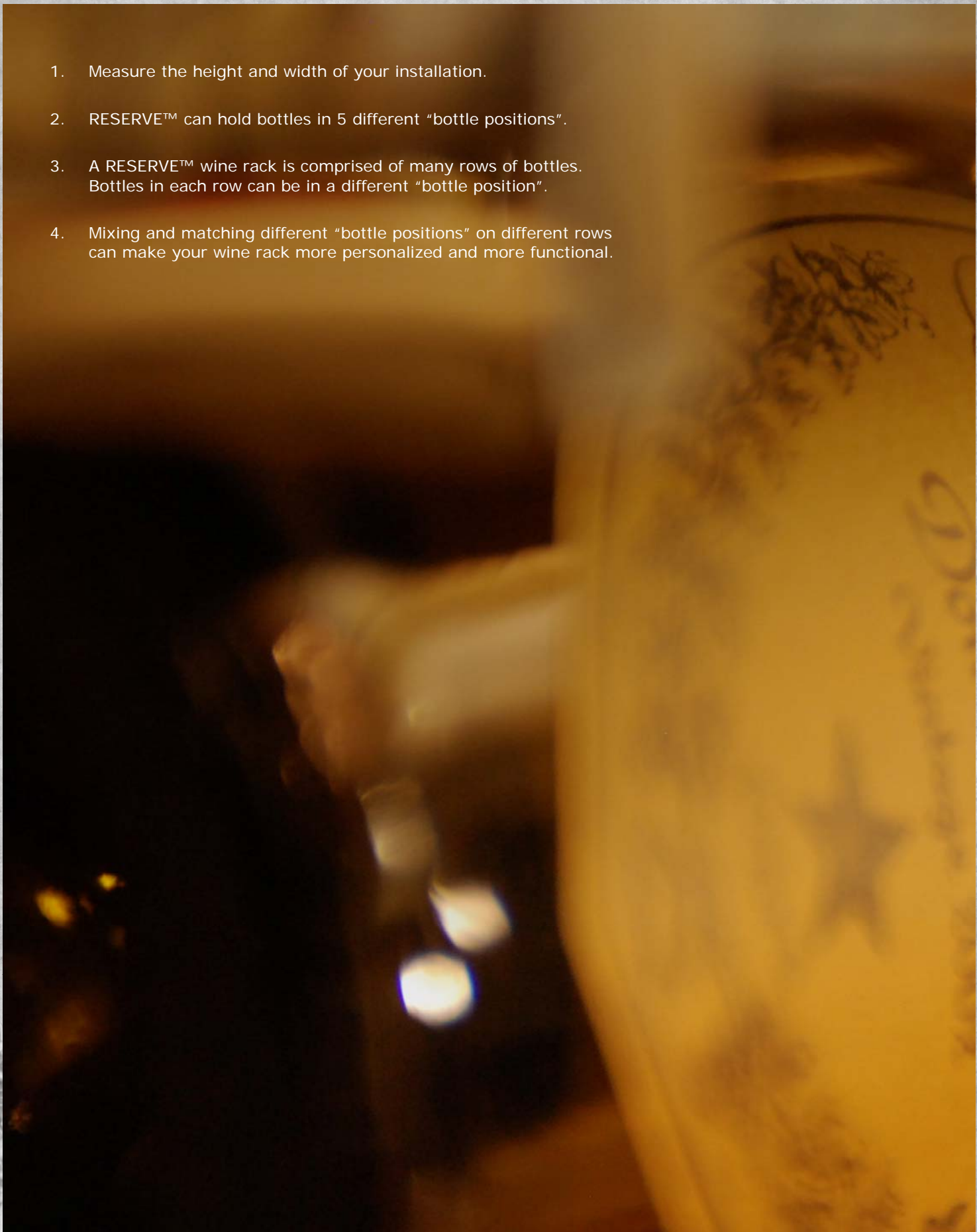

1. Whether you are designing an entire room or just a single wall, treat each wall separately.

- One wine rack can be comprised of many rows of bottles.
- Bottles in each row can be in a different position.
- Mixing and matching different bottle positions on different rows can make your wine rack more personalized and functional.

2. Calculate the usable wall height

- Measure the height of the wall. Remember to deduct the height of any base molding and/or crown molding.
- Helpful Hint: Measure both the left side and the right side of a wall, just in case there is any variation in wall height. Use the lesser of the 2 measurements for your design.

3. Measure the width of the wall

- This determines the length of the cross bars.
- The length of a cross bar should be approximately 1-1/2" longer than the distance between the centerlines of the outermost standards. This will allow for approximately 1/4" overhang of the cross bars per side. Cross bars should not be more than 12" longer (which equates to 6" overhang per side) otherwise instability may occur if a single bottle is left on the end. For example, if the distance between the outermost standards is 100", the length of the cross bars should be no less than 101-1/2" and not more than 112".
- Helpful Hint: Extended End Caps may be used which add 1" length per side to the cross bar. This can save cutting since standards come in only 24" increments.

4. Locate studs on the wall

- Try to position your wine rack so it lands on the maximum number of studs.
- Place one "standard" on the left most side of your wine rack and one "standard" on the right most side of your wine rack.
- Place additional standards in between.
- IMPORTANT: ADJACENT STANDARDS CANNOT BE SPACED MORE THAN 48" APART ELSE FAILURE MAY OCCUR. Standards may be spaced closer as needed.

5. Decide how you would like your wine rack to look and function

- Start at the bottom of the wine rack and choose the bottom most row's "bottle position".
- RESERVE™ can hold bottles in 5 different "bottle positions".
- A RESERVE™ wine rack is comprised of many rows of bottles.
- Bottles in each row can be in a different "bottle position"
- The next page shows how much height on a "standard" a particular bottle position will occupy.
- Choose the bottle position of the next higher row up and so on, until you reach the top of the wall.

6. How do I handle inside wall corners?

- If you have wine racks on perpendicular walls that meet at an inside corner, it is customary to allow the wine rack on the wider of the two walls to extend all the way to the corner.
- The wine rack on the shorter wall should stop short of the inside corner to allow for access to the bottles on the wine rack that is on the wider wall.

7. How do I handle outside wall corners?

- Wine racks on both walls can go all the way to the corner.

8. Helpful hints:

- Our "Standing View" bottle position uses a glass surface to hold the bottle upright. The glass surface also works great as a table or counter surface. Consider positioning it at 30" for table height or 42" for counter height.
- The "Presentation View" bottle position is great for lower rows since it makes the bottle's label easy to view and the bottle easy to reach down for.
- The "Label View" bottle position is great for higher rows since it makes the bottle's label easy to view and the bottle easy to reach up for.
- If you prefer to have an entire wall of standing bottles, contact us for our low profile glass shelving which is only 6" deep and is great for holding a single row of bottles across a wall—commonly seen in liquor bars.

- **Customizable**
 - Intelligent modular design allows each installation to be unique and precisely fitted to its space - much like a custom tailored suit.
 - All structural elements can be cut to fit the exact height and width of your space

- **Fits any size space, big or small**
 - Outfit an entire room to create a wine cellar.
 - Outfit a single wall to create a wall of wine. Low profile rack protrudes only 6" from wall.
 - Outfit a small space on a wall to create a personal wine bar, as small as 4' wide.

- **5 Bottle Positions**
 - Holds the bottle in 5 "bottle positions" for endless design possibilities.
 - A RESERVE™ wine rack is comprised of many rows of bottles. Bottles in each row can be in a different "bottle position".
 - Each "bottle position" showcases the bottle and its label, for easy viewing.

- **Glass Shelving**

The "Standing View" bottle position incorporates a glass shelf that can also be used as a counter or table surface for glasses, decanters, cork screws, etc.

- **Chrome**

RESERVE™ is made from beautiful chrome plated steel for a clean, elegant and modern aesthetic that will not deteriorate in damp spaces.

- **Easier Installation**

RESERVE™ requires up to 75% less mounting points compared to other brands.

- **Versatility**

As a wine collection evolves, RESERVE™ can easily be changed on the fly. For example, when starting a wine collection a person may prefer their collection to appear fuller. Accordingly a bottle position with a lower bottle density (bottles per square foot of wall) can be used, such as "Label View (1 Bottle Deep)". As the collection grows fuller, more bottles can be added by changing to a bottle position with a higher bottle density, such as "Label View (2 Bottle Deep)" or "Label View (3 Bottle Deep)" or "Presentation View". Changing the bottle position is as simple as turning a thumb screw and changing a bracket - no tools required.

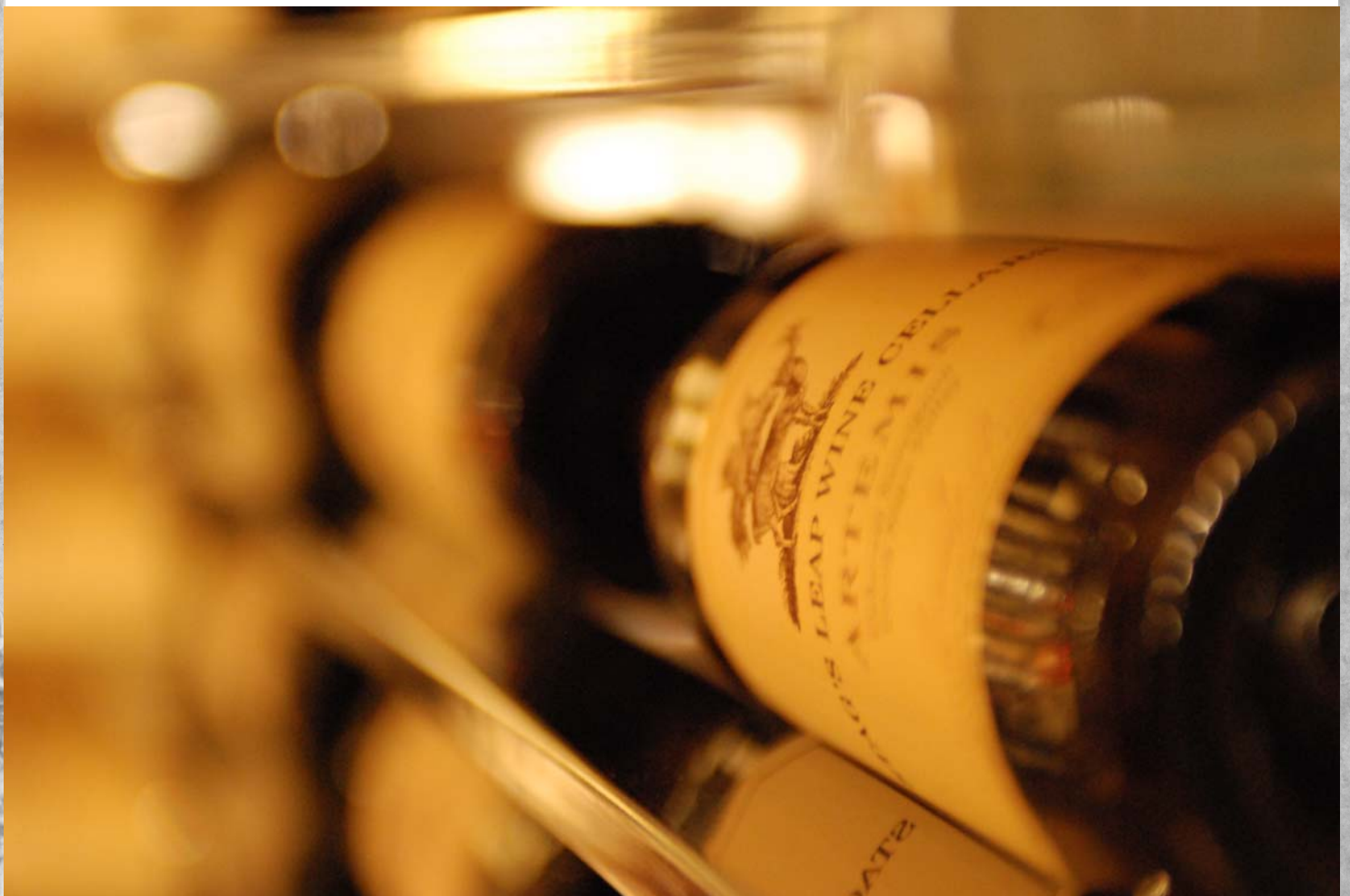

	Protrudes from Wall	Repeat Height	Keeps Cork Wet	Holds Magnum Bottles	Holds Champagne Bottles	Expand-able	Bottle Density	Relative Cost
Label View 1 Bottle Deep	6.75"	4"	✓	✓	✓	✓ from 1 to 3 bottles deep	 3 bottles per SF of wall	\$\$\$

Helpful Hints

- Use more of this bottle position if you prefer to have your wine rack appear more filled
- This bottle position is expandable to "2 Bottle Deep" and "3 Bottle Deep"
- Use this bottle position if your space has limited depth, therefore a low profile wine rack would work best

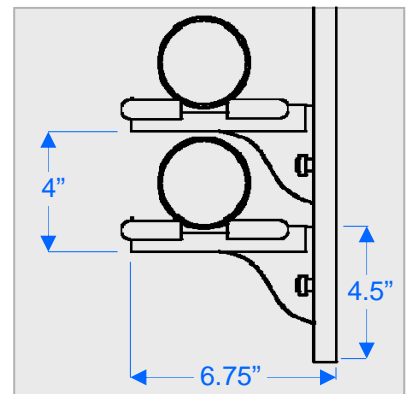
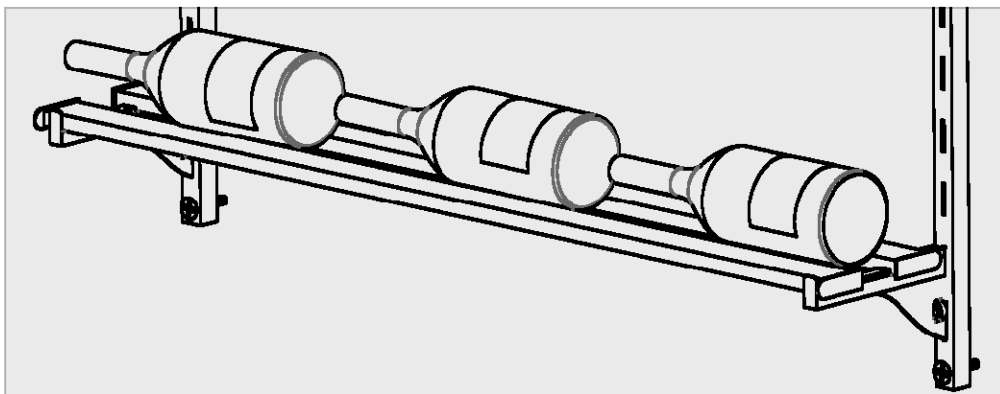

	Protrudes from Wall	Repeat Height	Keeps Cork Wet	Holds Magnum Bottles	Holds Champagne Bottles	Expand-able	Bottle Density	Relative Cost
Label View 2 Bottle Deep	10"	4"	✓	✓	✓	✓ from 2 to 3 bottles deep	6 bottles per SF of wall	\$\$\$\$

Helpful Hints

- This bottle position is expandable to "3 Bottle Deep"
- Allows plenty of air movement for proper aging of bottles

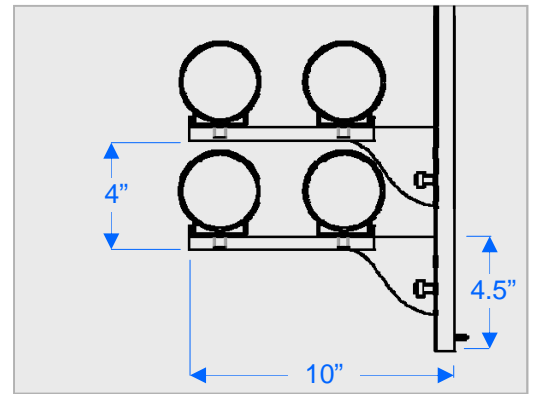
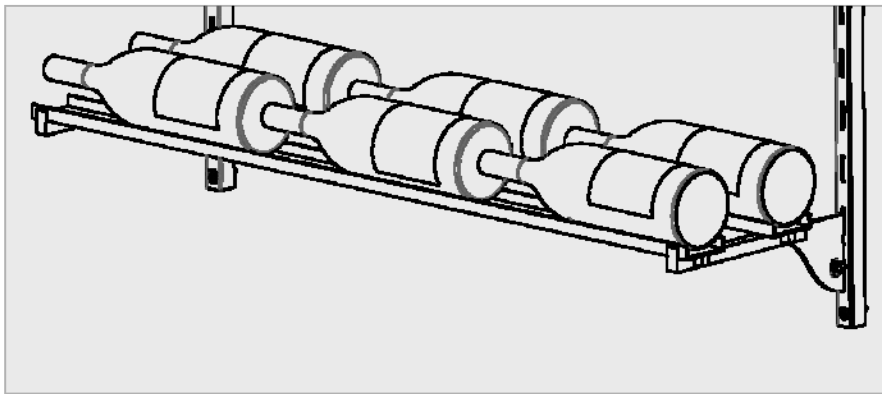

	Protrudes from Wall	Repeat Height	Keeps Cork Wet	Holds Magnum Bottles	Holds Champagne Bottles	Expand-able	Bottle Density	Relative Cost
Label View 3 Bottle Deep	15"	4"	✓	✓	✓	✓	9 bottles per SF of wall	\$\$\$\$\$

Helpful Hints

- This bottle position is extremely dense and yet attractive
- Allows plenty of air movement for proper aging of bottles

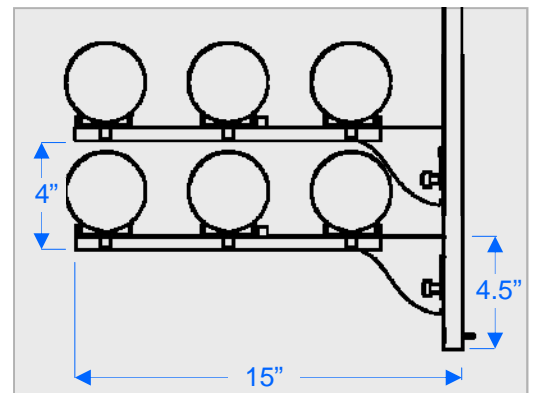
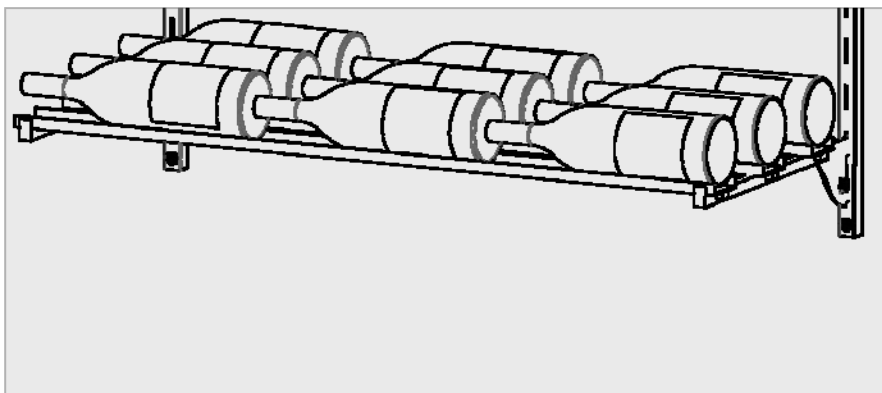

	Protrudes from Wall	Repeat Height	Keeps Cork Wet	Holds Magnum Bottles	Holds Champagne Bottles	Expand-able	Bottle Density	Relative Cost
Presentation View	17"	8"	 cork partially wet*			no	 5 bottles per SF of wall	

Helpful Hints

- This bottle position is great for rows lower than chest height since it makes the bottle's label easy to view and the bottle easy to reach down for.
- If your wall has a base molding, this bottle position is great as the bottom most row since it cleverly uses up the space that would otherwise be wasted (the bottles will hang "downward" over the base molding)

* In Presentation View, the cork will remain partially wet if the bottle is first turned horizontal, then rotated slightly upward, before placing into the Presentation View rack. This technique pushes the air bubble that is normally trapped at the top of the bottle to move to the middle of the bottle, thereby allowing the cork to become partially wet.

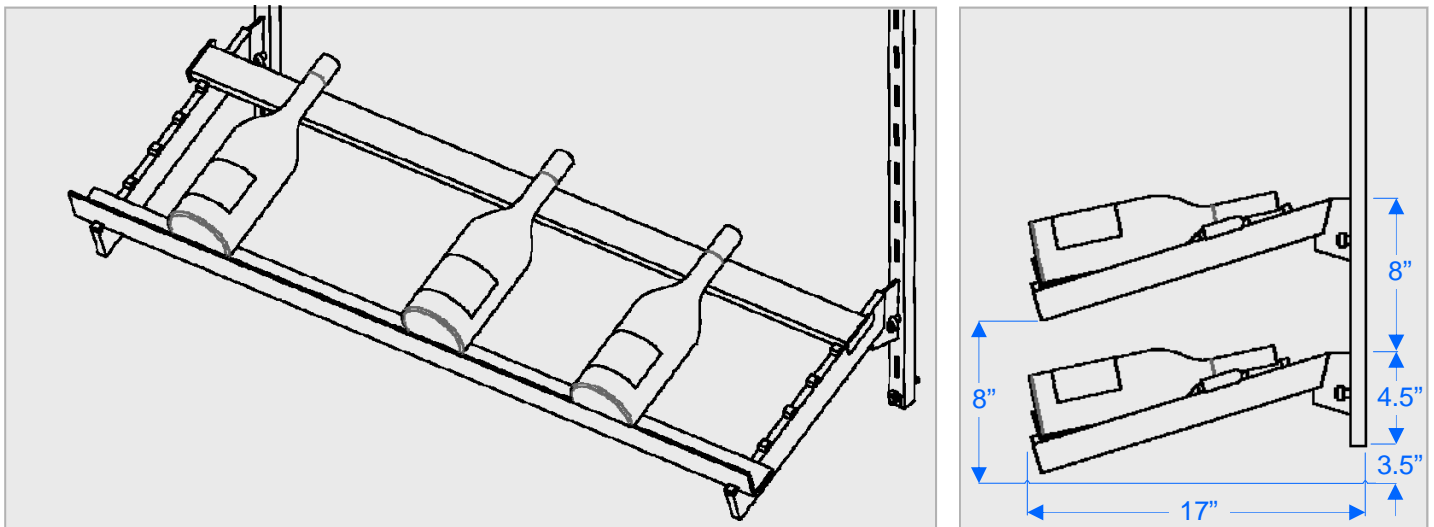

	Protrudes from Wall	Repeat Height	Keeps Cork Wet	Holds Magnum Bottles	Holds Champagne Bottles	Expand-able	Bottle Density		Relative Cost
Standing View	14" Standard or 5" Low Profile	14"	no			from 1 to 4 bottles deep	1 Bottle Deep	 3.2 bottles per SF of wall	
							2 Bottles Deep	 6.4 bottles per SF of wall	
							3 Bottles Deep	 9.6 bottles per SF of wall	
							4 Bottles Deep	 12.8 bottles per SF of wall	
Helpful Hints	<ul style="list-style-type: none"> • This bottle position is great for bottle display as well as being a beautiful glass serving surface - and even storage area for wine accessories such as glasses, decanters, etc. • Consider positioning this row 30" from the ground to use as a table surface • Consider positioning this row 42" from the ground to use as a counter surface 								

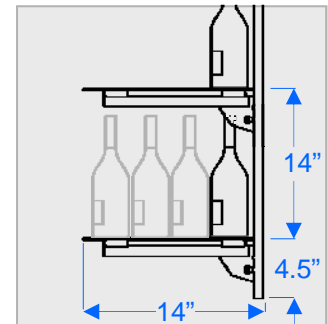
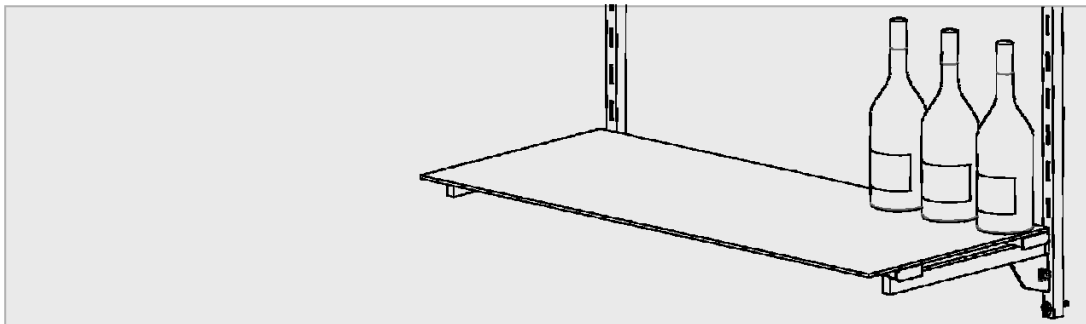

	Protrudes from Wall	Repeat Height	Keeps Cork Wet	Holds Magnum Bottles	Holds Champagne Bottles	Expand-able	Bottle Density	Relative Cost
Cork View	14"	4"	✓	✓	✓	no	 11.2 bottles per SF of wall	\$\$\$

Helpful Hints

- Use this bottle position if you like the look and function of traditional wine storage

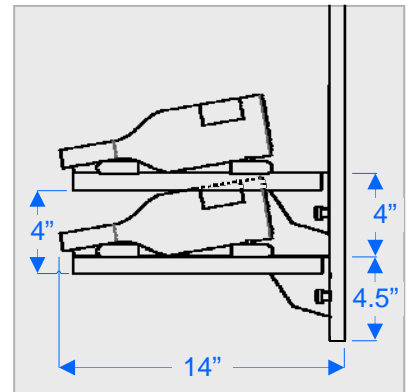
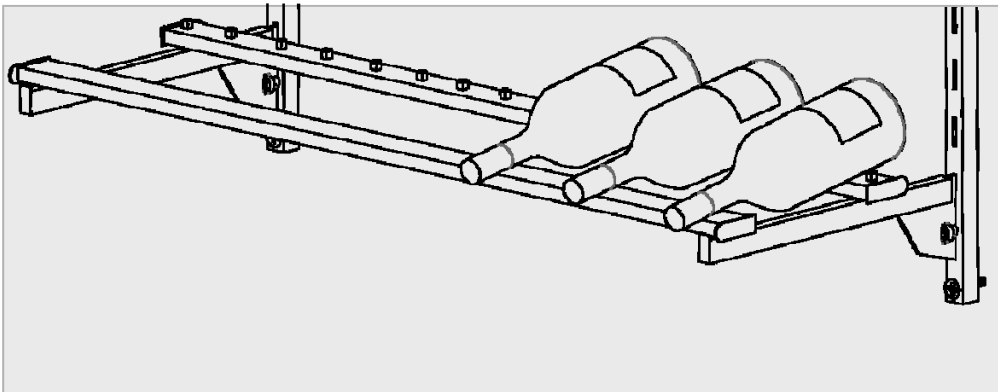







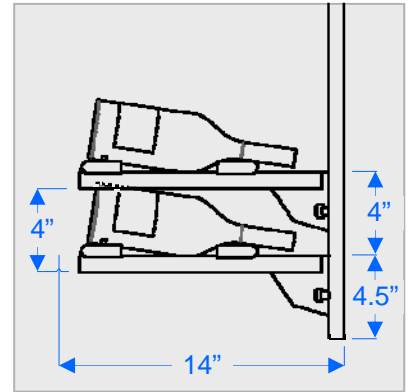
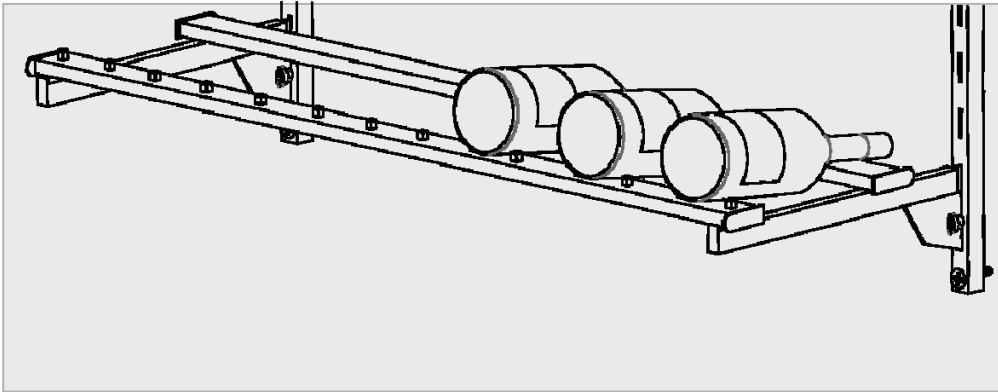







	Protrudes from Wall	Repeat Height	Keeps Cork Wet	Holds Magnum Bottles	Holds Champagne Bottles	Expand-able	Bottle Density	Relative Cost
Bottom View	14"	4"	✓	✓	✓	no	 11.2 bottles per SF of wall	\$\$\$

Helpful Hints

- Use this bottle position if you like the look and function of traditional wine storage



Compare

Bottle Position	Protrudes from Wall	Repeat Height	Keeps Cork Wet	Holds Magnum Bottles	Holds Champagne Bottles	Expand-able	Bottle Density	Relative Cost
 Label 1 Bottle Deep	6.75"	4"	✓	✓	✓	✓	 3 bottles per SF of wall	\$\$\$
Label 2 Bottle Deep	10"	4"	✓	✓	✓	✓	 6 bottles per SF of wall	\$\$\$\$
Label 3 Bottle Deep	15"	4"	✓	✓	✓	✓	 9 bottles per SF of wall	\$\$\$\$\$
 Presentation	16"	8"	✓ <small>*cork is partially wet</small>	✓	✓	no	 5 bottles per SF of wall	\$\$
 Standing 1 Bottle Deep	14" Standard OR 5" Low Profile	14"	no	✓	✓	✓	 3.2 bottles per SF of wall	\$
Standing 2 Bottle Deep	14" Standard OR 5" Low Profile	14"	no	✓	✓	✓	 6.4 bottles per SF of wall	\$
Standing 3 Bottle Deep	14" Standard OR 5" Low Profile	14"	no	✓	✓	✓	 9.6 bottles per SF of wall	\$
Standing 4 Bottle Deep	14" Standard OR 5" Low Profile	14"	no	✓	✓	✓	 12.8 bottles per SF of wall	\$
 Cork	14"	4"	✓	✓	✓	no	 11.2 bottles per SF of wall	\$\$\$
 Bottom	14"	4"	✓	✓	✓	no	 11.2 bottles per SF of wall	\$\$\$

* In Presentation View, the cork will remain partially wet if the bottle is first turned horizontal, then rotated slightly upward, before placing into the Presentation View rack. This technique pushes the air bubble that is normally trapped at the top of the bottle to move to the middle of the bottle, thereby allowing the cork to become partially wet.



How was this wine cellar designed?

This wine cellar is a great example of how the RESERVE™ Wine Rack can be custom fitted into a space to create a beautiful wine cellar. Every inch of wall space has been fitted with bottles.

■ Side Walls

- 4 rows of the “Presentation View” bottle position were used starting from the ground up. The “Presentation View” bottle position is great for lower rows since it makes the bottle’s label easy to view and the bottle easy to reach down for.
- The “Standing View” bottle position was used for the 5th row from the bottom creating a counter surface at approximately 42”H which not only holds bottles but also glasses, decanters, cork screws and other wine accessories.
- The “Label View” bottle position was used for the top half of the wall. The “Label View” bottle position is great for higher rows since it makes the bottle’s label easy to view and the bottle easy to reach up for.
- The “Standing View” bottle position was used again for the top most row to hold decorative wine boxes for a finishing touch.

■ Small Facing Wall (bottles with orange labels)

- The “Label View” bottle position was used for the entire wall.
- Notice the small angled wall on the left side. The RESERVE™ Wine Rack was fitted perfectly to the wall allowing the bottles to follow the exact angle of the wall.

■ Back Wall

- The “Label View” bottle position was used for the entire wall.
- Notice how some walls are angled. The RESERVE™ Wine Rack was fitted perfectly to the wall size allowing the bottles to follow the exact angle of the walls.
- A glass shelf (the “Standing View” bottle position) was placed at approximately 30” allowing for a table surface to place a wine box and a large focus bottle.



How was this wine cellar designed?

This installation is the same as the previous but was photographed in the dark to show the dramatic lighting employed in the room. The "Label View" bottle position was selected for the entire wall. The lighting was created by low profile led light strips installed behind the large showcase bottle. These types of light strips are available at most large hardware stores or specialty lighting retailers. Optionally, frosted glass was then mounted on top of the LED lights in order to diffuse the light. The effect, when viewed in a dark room, is a subtle and dramatic glow of light which does not harm the wine.

The standards (the vertical elements of the wine rack) are 0.70" deep. This space is ideal to put creative elements into your wine rack such as lighting, mirrors, decorative surfaces, etc. The standards can be further distanced from the wall by using a suitable spacer element thereby creating even more room for decorative ideas.



How was this wine rack designed?

This wine cellar is a great example of how the RESERVE™ Wine Rack can be used in tight spaces not typically thought of as places for wine bottles. This installation is in a condominium in New York City where space is a premium. The 54" wide corridor was largely unused and held basic art on the wall. Since the "Label View" bottle position only protrudes 6.75" from the wall, very little of the precious corridor space was taken up. The end result was a dramatic and very smart utilization of the wall.



How was this wine rack designed?

This installation is a great example of putting wine bottles in non-traditional places. Even a small apartment can have a wine bar that is functional yet beautiful. The RESERVE™ Personal Wine Bar shown above is 48”H and 48”W. The Personal Wine Bar can be customized to any size and hold any number of bottle positions. For the Personal Wine Bar shown above:

- The “Presentation View” bottle position was used for the bottom most row. The “Presentation View” bottle position is great for lower rows since it makes the bottle’s label easy to view and the bottle easy to reach down for.
- The “Standing View” bottle position was used as the next row up at approximately 42”H. The glass shelf is perfect to also double as a counter surface to hold glasses.
- The remaining rows are the “Label View” bottle position. The “Label View” bottle position is great for higher rows since it makes the bottle’s label easy to view and the bottle easy to reach up for.



How was this wine rack designed?

The RESERVE™ Personal Wine Bar works great when paired along with a traditional counter style bar. When placed on a wall next to a bar, wine bottles are stored conveniently and shown beautifully. The RESERVE™ Personal Wine Bar shown above is 48"H and 48"W. The Personal Wine Bar can be customized to any size and hold any number of bottle positions. For the Personal Wine Bar shown above:

- The "Label View" bottle position was chosen for all rows. The "Label View" bottle position is great since it makes the bottle's label easy to view and the bottle easy to reach for.



How was this wine rack designed?

This Liquor Bar was created using 3 rows. Each row is a glass shelf that holds the bottle in the "Standing View" bottle position. The Glass Shelf is available in standard 14" depth or special 5" depth. Mirrors placed in between the Standards (the vertical elements of the wine rack) offer a beautiful depth to the bar. The standards are 0.70" deep. This space is ideal to put creative elements into your wine rack such as lighting, mirrors, decorative surfaces, etc. The standards can be further distanced from the wall by using a suitable spacer element thereby creating even more room for decorative ideas.



How was this wine rack designed?

This wall of wine uses 6 rows of bottles.

- The bottom 4 rows are the “Presentation View” bottle position. The “Presentation View” bottle position is great for lower rows since it makes the bottle’s label easy to view and the bottle easy to reach down for.
- The “Standing View” bottle position was used as the next row up at approximately 42”H. The glass shelf is perfect to also double as a counter surface to hold wine accessories.
- The remaining rows are the “Label View” bottle position. The “Label View” bottle position is great for higher rows since it makes the bottle’s label easy to view and the bottle easy to reach up for.



How was this wine rack designed?

This installation is a good example of how the RESERVE™ Wine Rack can fit 2 walls coming together at an angle. All rows are the "Label View" bottle position. Notice the 2 Standards (the vertical elements of the wine rack) side by side. Each standard is on it's own wall thereby in essence being it's own wine rack. By treating each wall separately, your wine rack can follow the wall all the way around a room no matter which direction the wall goes.



How was this wine rack designed?

This installation shows the "Standing View" bottle position using our special order low profile 6" deep glass shelving rather than our traditional 12" deep glass shelving. The lower profile glass shelving is great if only bottles are to be stores and additional room for accessories on the glass shelving is not needed.

1. Contact us for pricing (M-F 8:00am - 4:30pm EST)

- Phone: 1.888.98.DGEAR (983.4327)
- Email: help@diamondlifegear.com
- Chat: click "chat" link on left side of any page on our website

2. The following information will help us design and price your wine rack

- Height
- Width
- Desired Bottle Positions (we can help with this)

3. Place your order

★ **We'll build and ship your wine rack within 7-10 business days**



Note how the Spartans fell. They added to their other brutish qualities, an abstinence from wine. With what result? Their power was extinguished and they died out. Some brief generations after their chief victories, they had dwindled to a few hundred men and soon after, none were to be found. They had perished. Nor have they left any memory or monument. Athens, august in the use of wine, is gloriously immortal. But who reads or remembers Lacedaemon? Where are its songs, its visions, its philosophy, its laughter, or its marbles? There are none known, for they had none. Lacking wine the Spartans could not create, and their city was transformed into a squalid hamlet. So much for the Spartans.

Anonymous



<p>Any questions or problems, please contact us:</p> <p>Gupta Permold Corporation Consumer Goods Division diamondLife™ Brand 234 Lott Road Pittsburgh, PA 15235 USA Ph. 1.888.98.DGEAR (983.4327) Fx. 412.793.1055 Email. help@diamondlifegear.com Store. diamondlifegear.com</p>	 <p>Find hundreds of more great work space enhancement products at</p> <hr/> <p>Doing a common thing uncommonly well, brings success.</p> <p>Welcome to the diamondLife.™</p>
--	--