

1. Identify all components

- Remove all components from their cartons
- Using the "Components" document included with your installation instructions, identify each component, and group like components together. Make sure you received the correct quantity of each component, as marked on the "Components Included" document.

2. Whether you are installing on multiple walls or just a single wall, treat each wall separately.

3. Locate where "standards" will be mounted on the wall

- Try to position your wine rack so it lands on the maximum number of studs
- If a standard falls in a location where there is no stud, use the appropriate wall anchor system to mount (typically found at your local hardware store). Be sure the fastener is "flat head" type.
- Place one standard on the left most side of your wine rack and one standard on the right most side of your wine rack
- Place additional standards in between
- **IMPORTANT: ADJACENT STANDARDS CANNOT BE SPACED MORE THAN 48" APART ELSE FAILURE MAY OCCUR.** Standards may be spaced closer together than 48". Please note that the horizontal cross bars would have been made to span the full width of your wine rack. Another words if your wine rack is 96" wide, your horizontal cross bars will be 96" wide, and you would have received 3 standards—one standard for the left and right sides and one standard to be in the middle.
- **IMPORTANT:** The width of your wine rack is dictated by the length of your horizontal cross bars. The centerline of the outermost standards must be located minimum 3/4" in from the end of the cross bars.

3. Mount "standards" onto wall

- Be sure that all standards on a wall are mounted exactly at the same height. This is the most critical part of the installation. Use a level or laser level to make sure the slots on all standards across a wall are horizontally aligned. Do not trust putting your standards on top of your base molding and assuming that they will be level. Base moldings can vary in height. Since this is the most critical part of the installation it is important to be extra careful.
- If the flatness of your wall varies by more than 1/4", the wine rack may not sit properly. In this case, use shims to push the lower-sitting standards further away from the wall so that all the standards are on one plane.
- Depending on the length of your standard, the mounting holes may not be symmetrical from each end of the standard. Try to mount all the standards so the mounting holes across all standards are aligned horizontally. Whichever end of the standard that has a mounting hole closest to it, should be used as the top end of the standard.
- Be careful that the mounting screws sit flush into the countersinks in the standards. If the screw heads sit crooked they may restrict some brackets from attaching properly. Therefore it is suggested to use a power drill with a 1/8" diameter drill bit and pre-drill the mounting holes into the wall, straight and perpendicular. This will ensure that the screws are not crooked and sit flush.
- The standards will be to the size you specified. If needed, the standards can be cut down by using a jig saw, circular saw, table saw, or band saw along with a saw blade designed to cut 1/8" thick steel
- If the top of the standards are near the ceiling, attach the desired top bracket onto the standards before mounting the standard onto the wall. After the standards are mounted, the ceiling may interfere with insertion of the bracket onto the standard.
- The standards can be painted to further blend into the wall.

4. Attach the "brackets" to the standard per your desired wine rack configuration

- Turn the thumb screw on the bracket to tighten and loosen. You do not need to over tighten the thumb screw. It is normal that the brackets have some free side-to-side movement after tightening.

5. Attach the "cross bars" onto the brackets using the integral magnets

- The cross bars will "snap" onto the brackets magnetically (similar to how an iPad™ Cover snaps onto an Apple® iPad™)
- The cross bars will be to the size you specified. If needed, the cross bars can be cut down by using a jig saw, circular saw, table saw, or band saw along with a saw blade designed to cut 1/8" thick steel
- Shorter cross bars can be "spliced" together to create longer cross bars. Simply tap a "splicer" half way into one end of a cross bar. Then tap your second cross bar onto the exposed half of the splicer.

6. Install the "end caps" onto the cross bars

- Use a soft hammer or mallet to nudge the end caps into both ends of the cross bar.
- For each cross bar, put the end caps facing in the same direction.
- Bundle up a towel and place it on the floor. Put one end of the cross bar on the bundled up towel and hammer in the end cap into the other end. The soft towel will help not to damage your floor and not to bend the end cap or cross bar during hammering.
- For best appearance, put adjacent cross bars in such a way that the end caps face in the opposite directions.

7. Place bottles!

Point camera at QR code



Inspiration

Fastening into wall stud

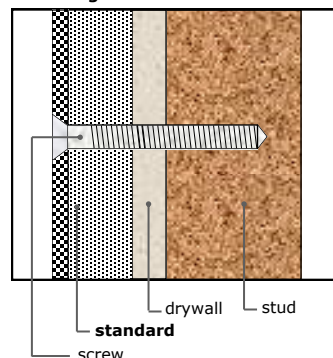

Any questions or problems, please contact us:

Gupta Permold Corporation
RESERVE™ Brand
234 Lott Road
Pittsburgh, PA 15235
USA
Ph. 1.888.98.DGEAR (983.4327)
Fx. 412.793.1055
Email. help@diamondlifecycle.com
Store. diamondlifecycle.com



Find thousands of more great work space enhancement products at www.diamondlifecycle.com

Doing a common thing uncommonly well, brings success.

Welcome to the diamondLife.™

Components Included

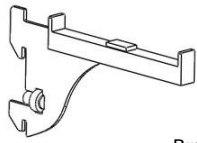

Bracket, Label View 1



Standard

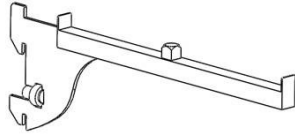

Bracket, Label View 2

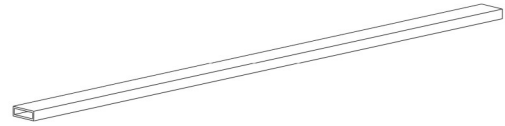

Cross Bar

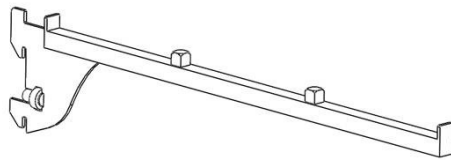

Bracket, Label View 3

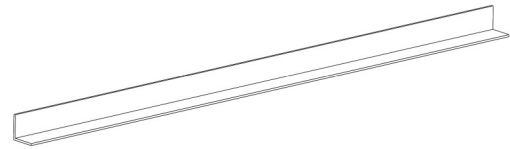

Angle

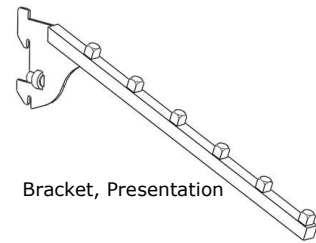

Bracket, Presentation

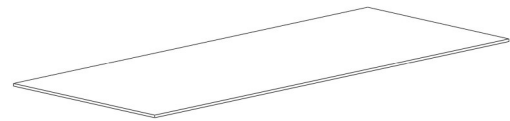

Glass

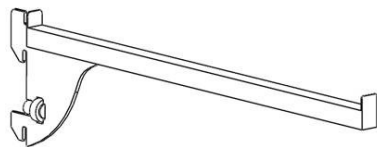

Bracket, Standing

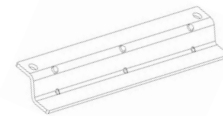

Splicer

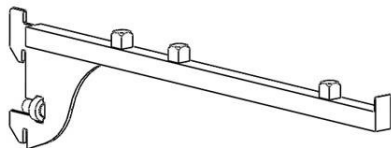

Bracket, Cork



End Cap

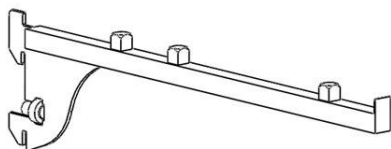

Bracket, Bottom

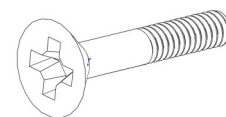

Screw

ORDER#

Carton List



Carton Number	Type	Size	Weight
	Box / Tube		
	Box / Tube		
	Box / Tube		
	Box / Tube		
	Box / Tube		
	Box / Tube		
	Box / Tube		
	Box / Tube		
	Box / Tube		
	Box / Tube		
	Box / Tube		
	Box / Tube		

ORDER#

Installation Instructions



Label View, 1 Bottle Deep	
Height Occupied on Standard	4.00"
Suggested Repeat Height	4.00"
Protrudes From Wall	6.75"

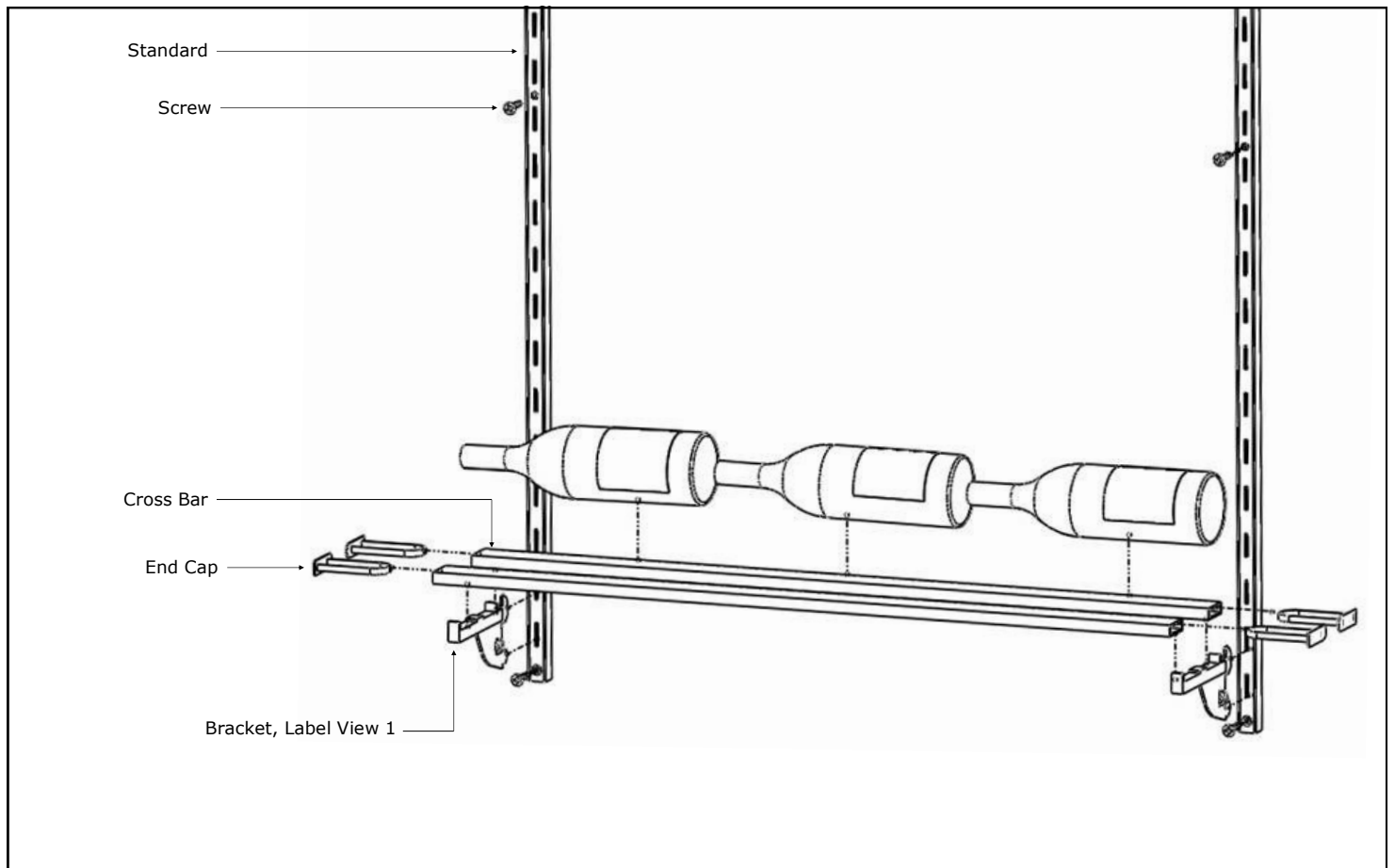
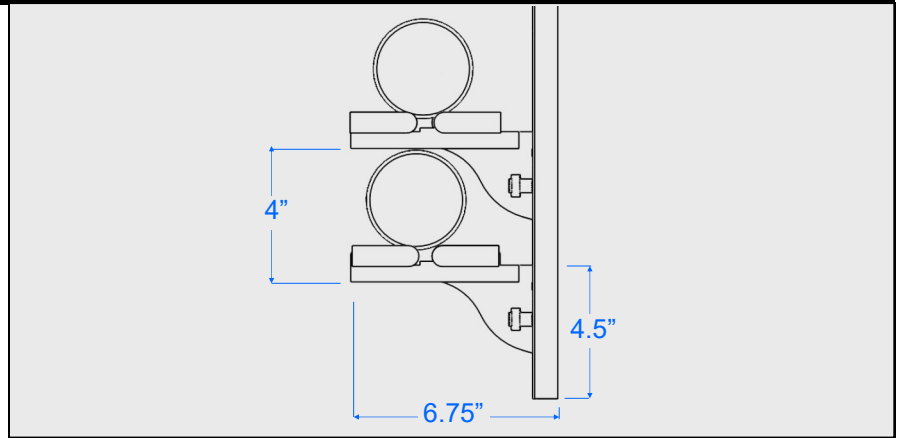

■ Please note that the diagram above shows a 48" wide wine rack example. Your horizontal cross bars would have been made to span the full width of your wine rack.

Installation Instructions



Label View, 2 Bottle Deep	
Height Occupied on Standard	4.00"
Suggested Repeat Height	4.00"
Protrudes From Wall	12.00"

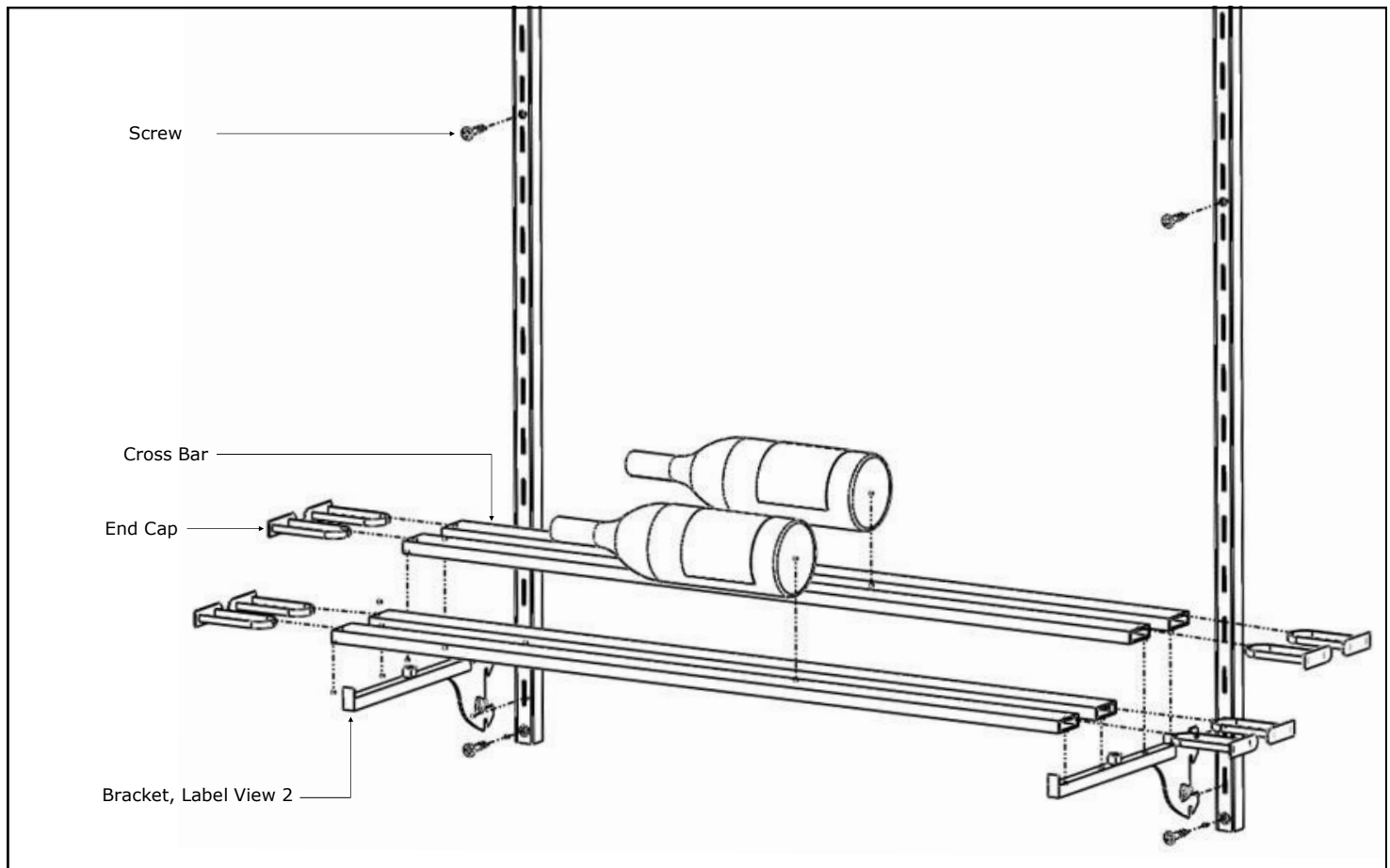
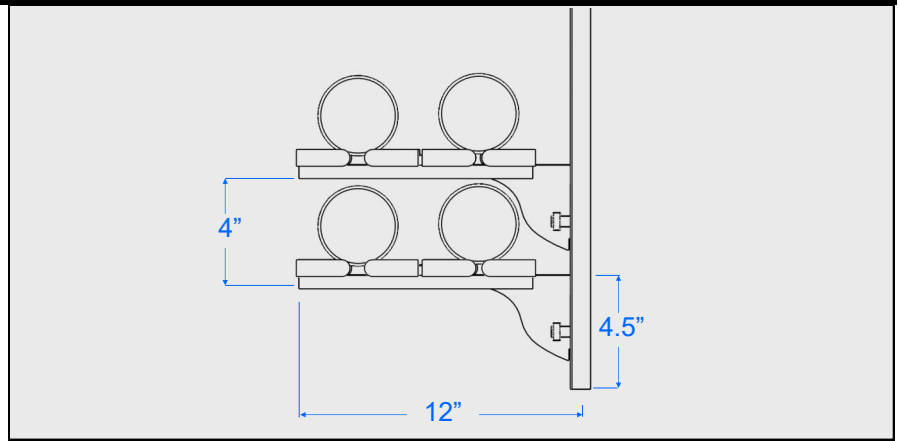

■ Please note that the diagram above shows a 48" wide wine rack example. Your horizontal cross bars would have been made to span the full width of your wine rack.

Installation Instructions



Label View, 3 Bottle Deep	
Height Occupied on Standard	4.00"
Suggested Repeat Height	4.00"
Protrudes From Wall	17.50"

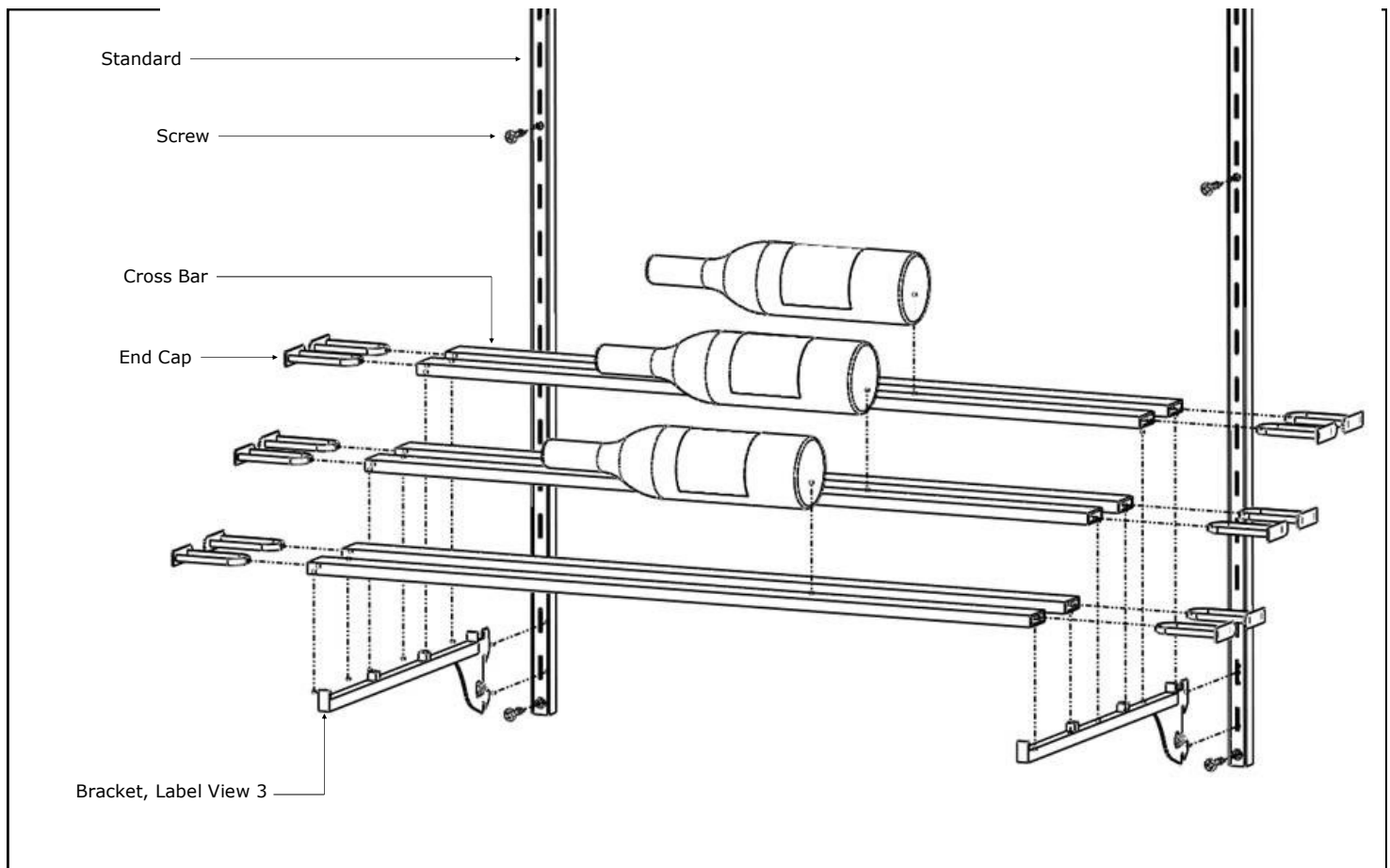
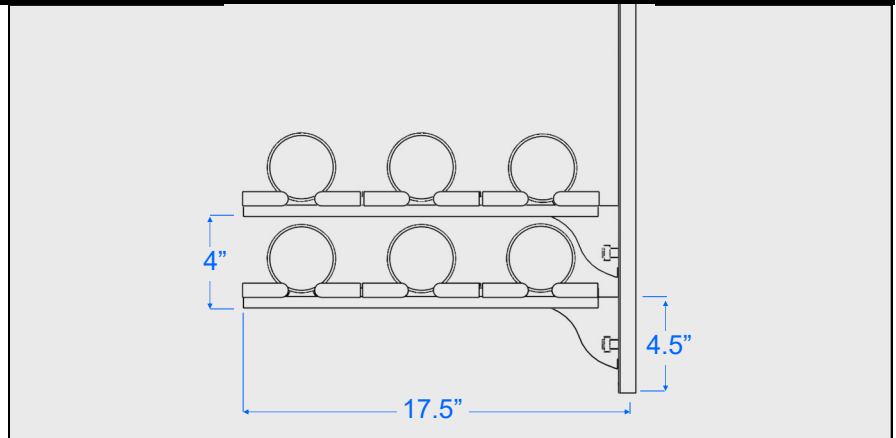

■ Please note that the diagram above shows a 48" wide wine rack example. Your horizontal cross bars would have been made to span the full width of your wine rack.

Installation Instructions



Presentation View	
Height Occupied on Standard	9.00"
Suggested Repeat Height	8.00"
Protrudes From Wall	14.00"
Helpful Hints:	
<ul style="list-style-type: none"> •If positioned as the bottom most row, the Presentation View row will hang down over your base molding 3.50" 	

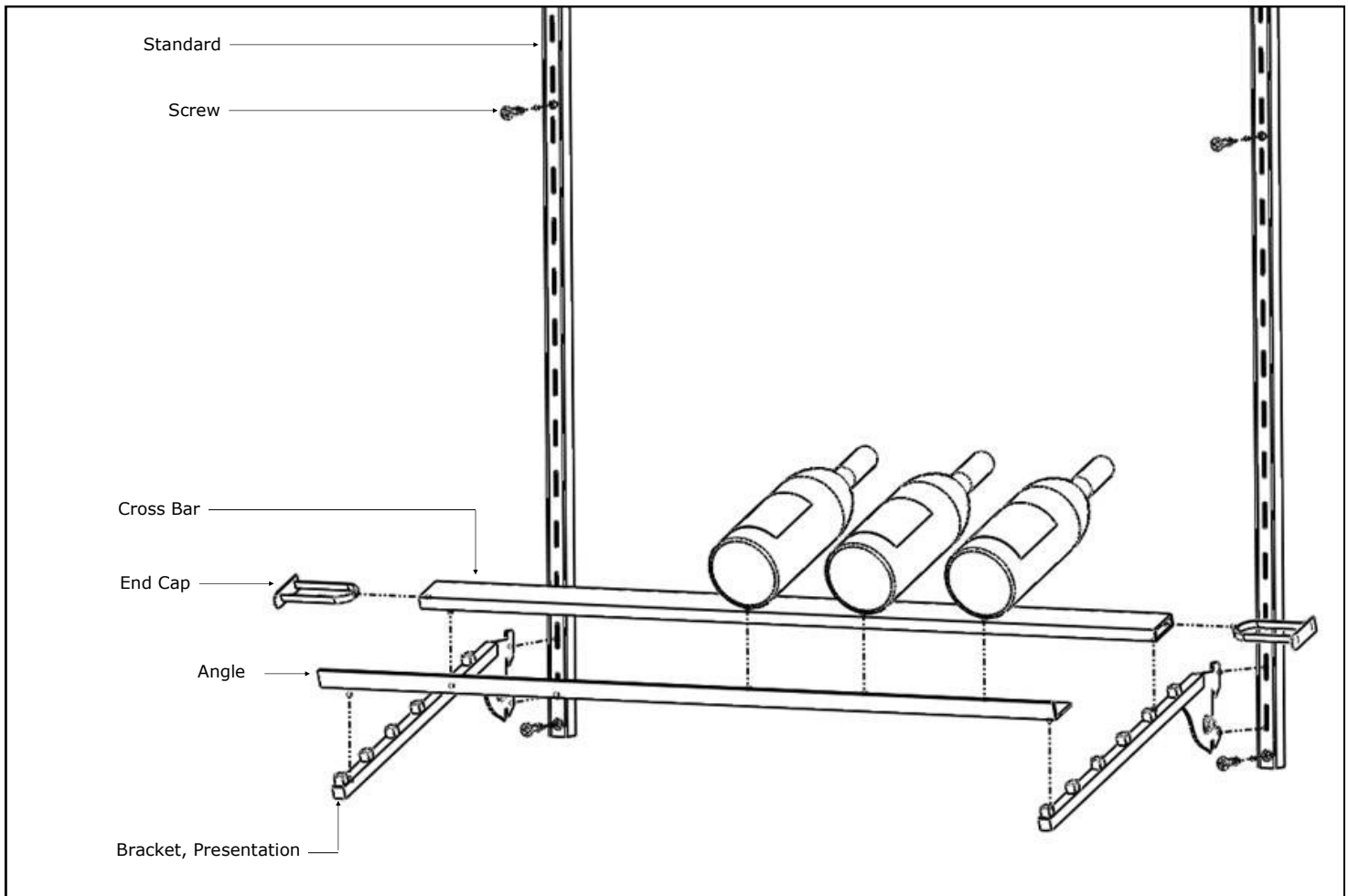
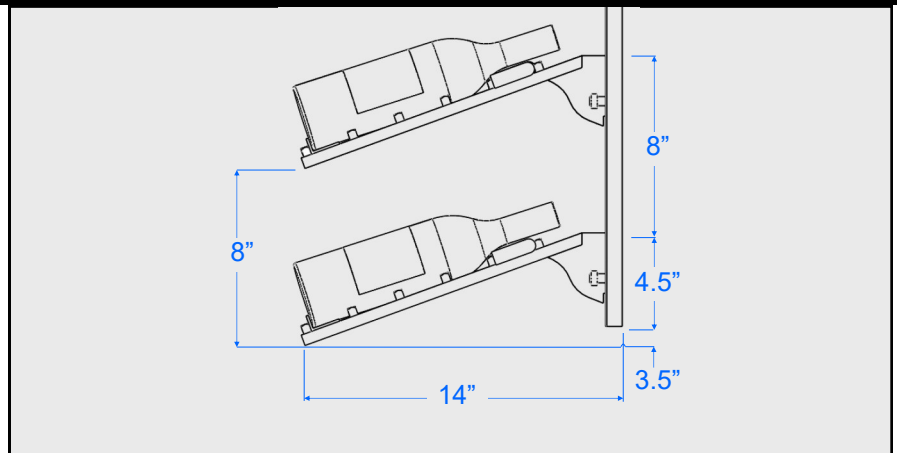

■ Please note that the diagram above shows a 48" wide wine rack example. Your horizontal cross bars would have been made to span the full width of your wine rack.

Installation Instructions



Standing View

Height Occupied on Standard	14.00"
Suggested Repeat Height	14.00"
Protrudes From Wall	14.00"

Helpful Hints:

- Most standard bottles are approximately 12" tall
- Position at 30" from ground to use as a table surface
- Position at 42" from ground to use as a counter surface

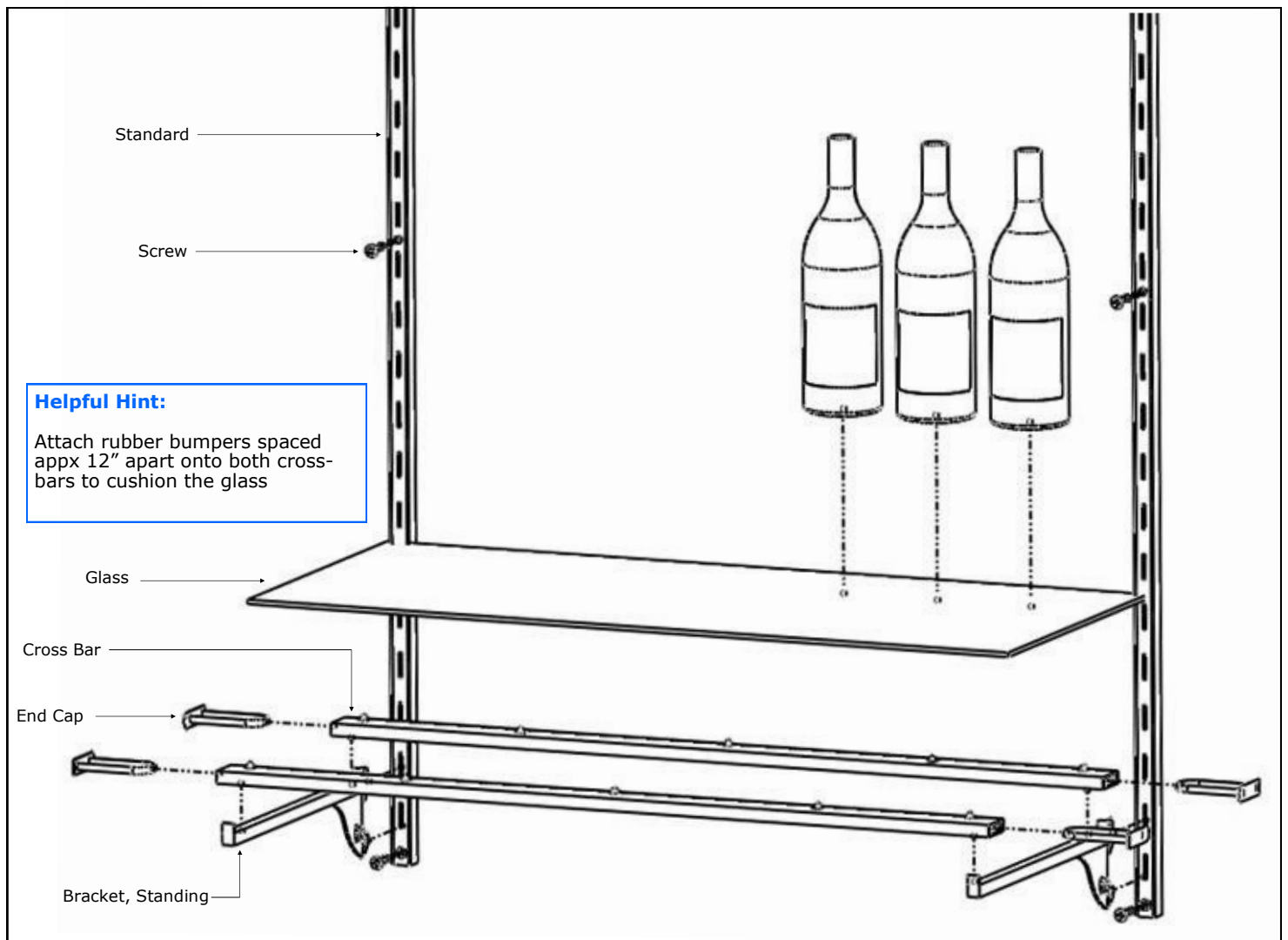
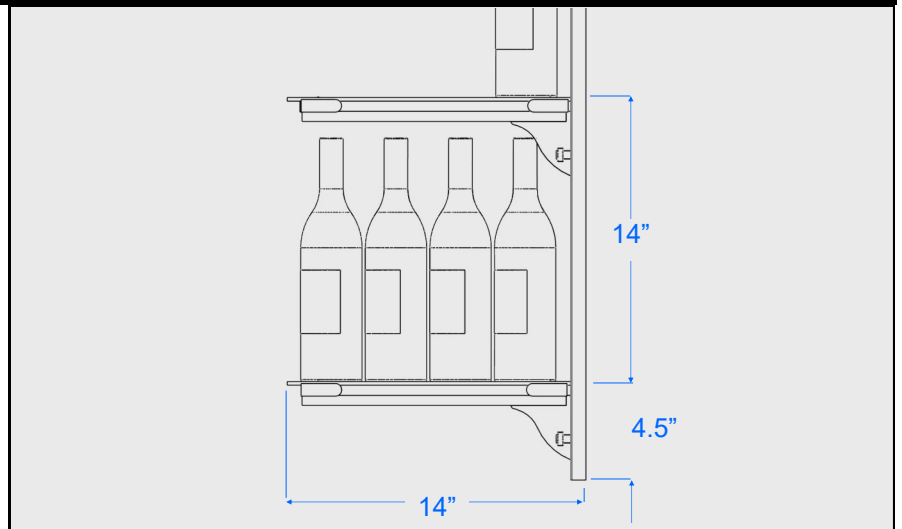

■ Please note that the diagram above shows a 48" wide wine rack example. Your horizontal cross bars would have been made to span the full width of your wine rack.

Installation Instructions



Cork View	
Height Occupied on Standard	4.00"
Suggested Repeat Height	4.00"
Protrudes From Wall	14.00"
Helpful Hint: Most standard bottles (750ml) are approximately 3" diameter	

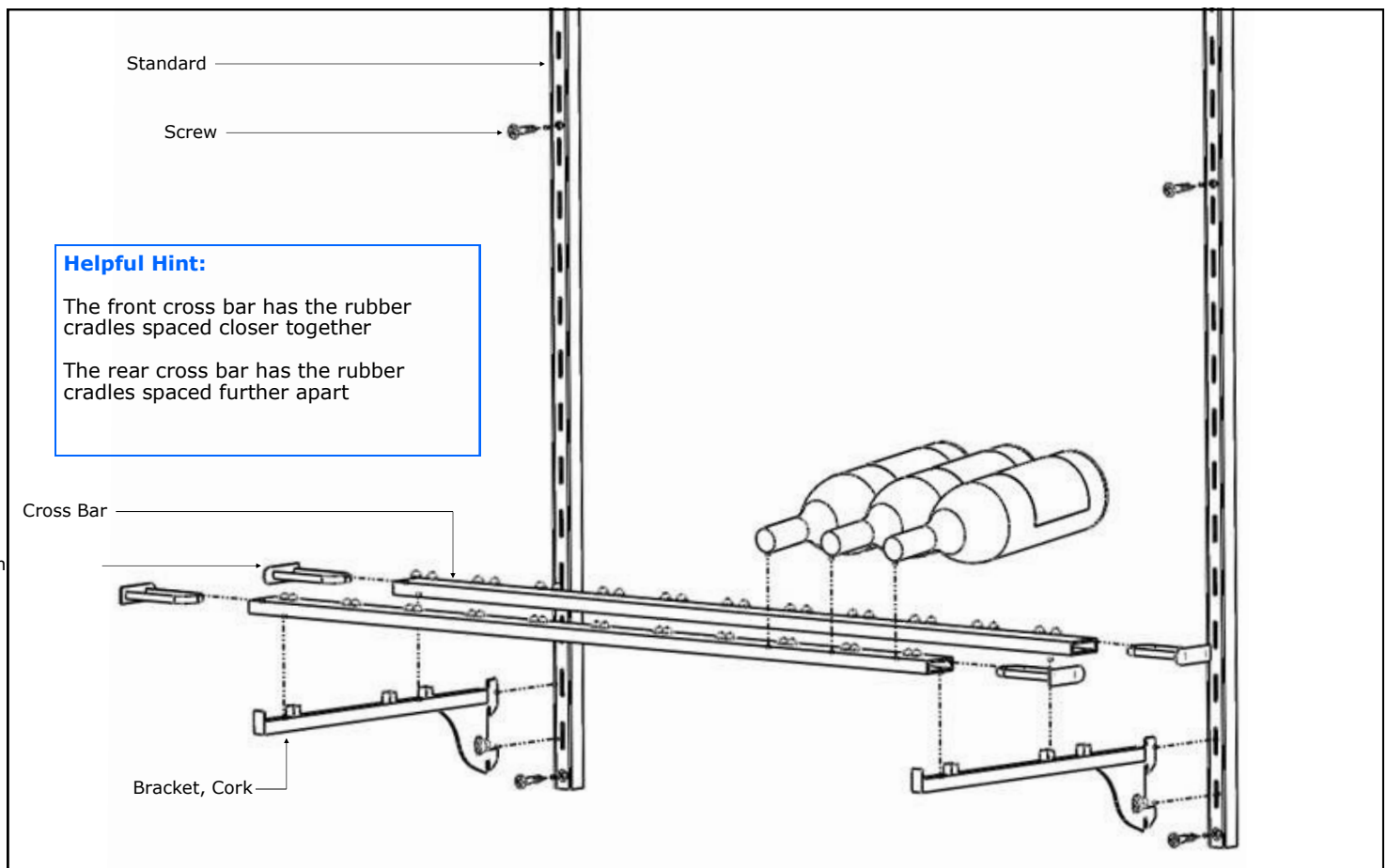
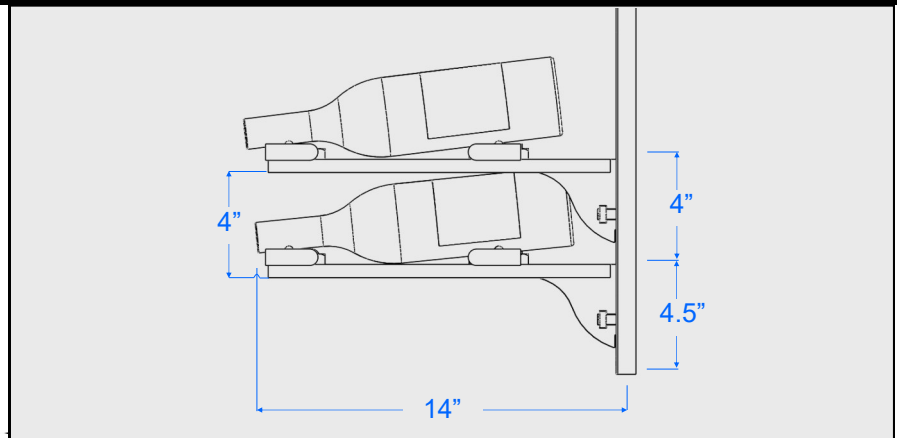

■ Please note that the diagram above shows a 48" wide wine rack example. Your horizontal cross bars would have been made to span the full width of your wine rack.

Installation Instructions



Bottom View	
Height Occupied on Standard	4"
Suggested Repeat Height	4"
Protrudes From Wall	14.00"
Helpful Hint: Most standard bottles (750ml) are approximately 3" diameter	

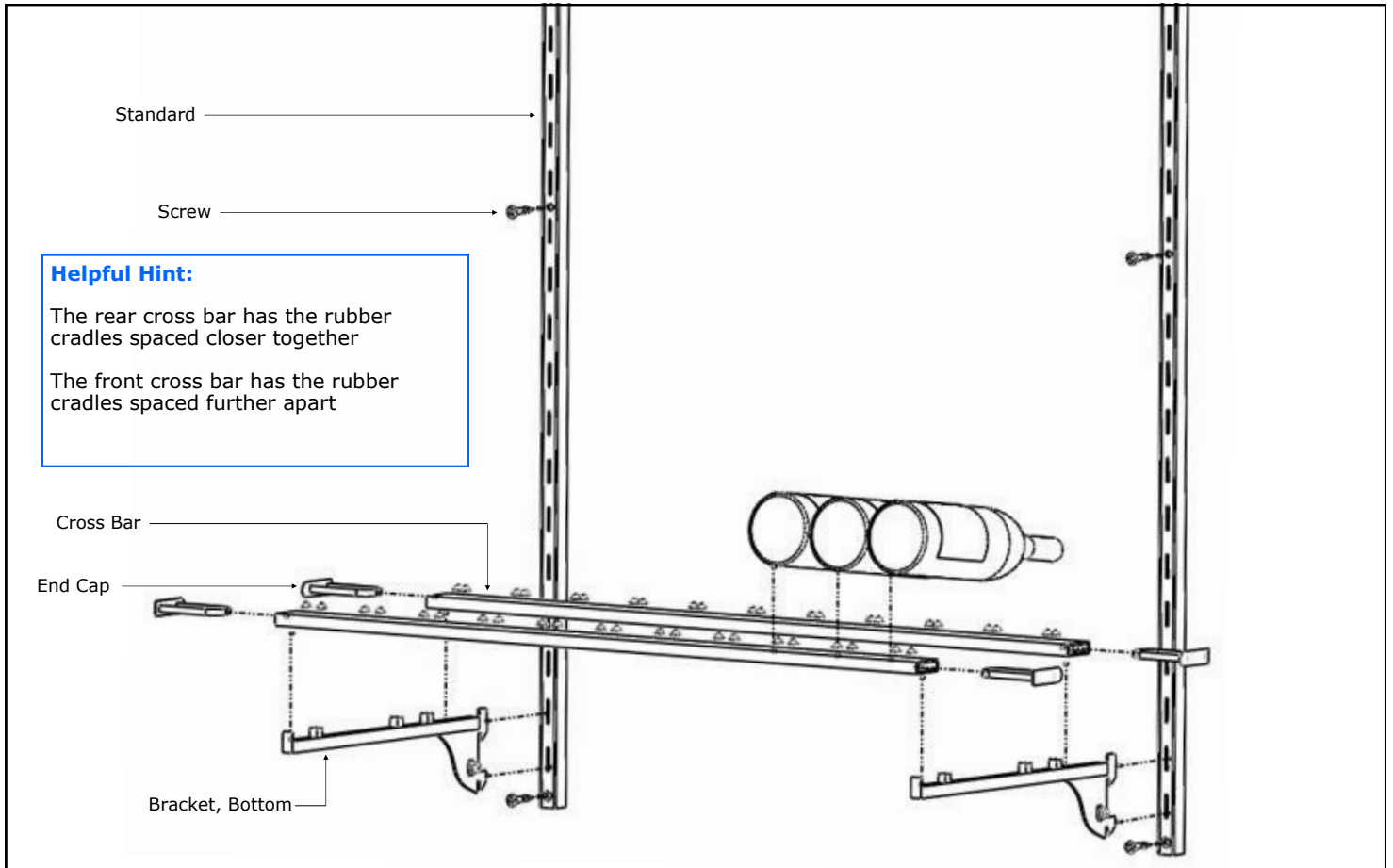
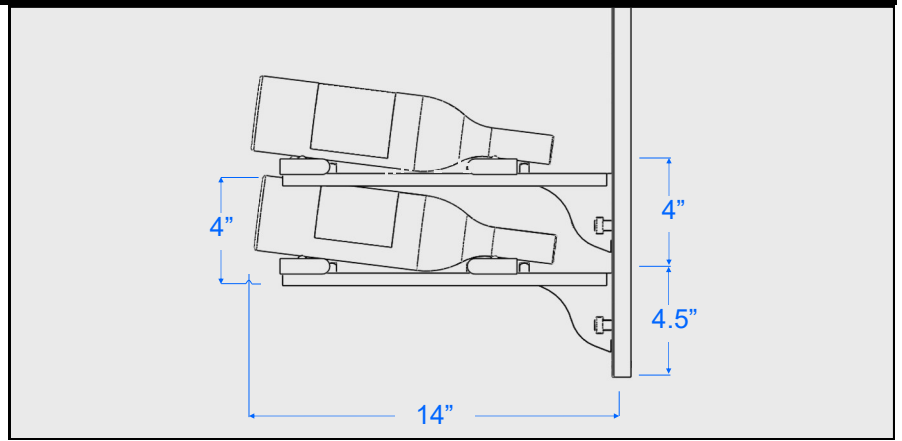

■ Please note that the diagram above shows a 48" wide wine rack example. Your horizontal cross bars would have been made to span the full width of your wine rack.